

AudioControl®

Making Good Sound Great™

Features

- Composite foam surround for smooth, controlled bass
- High-precision motor assembly improves efficiency and output
- Rigid steel basket for strength and reduced resonance
- High-temperature, lightweight voice coil
- Dual dust cap design for enhanced rigidity and heat dissipation
- Non-pressed paper cone for added warmth and depth
- Large-gauge, quick-release black nickel terminals
- Show Car approved

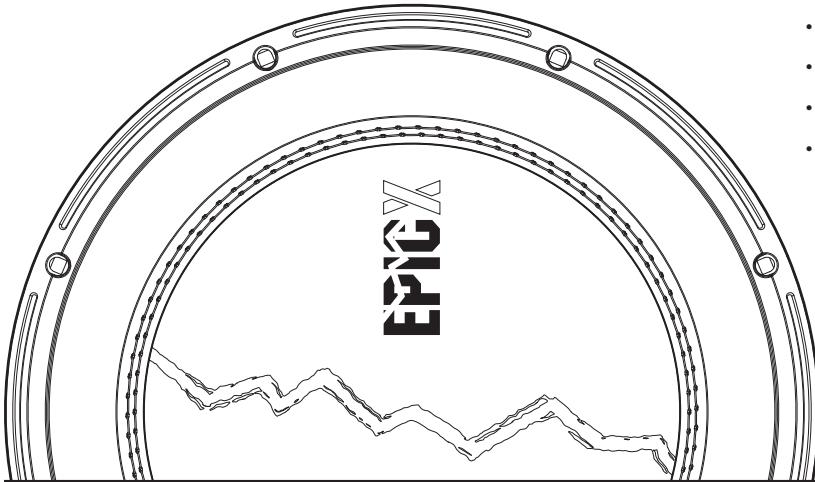

EPICX

STREETBASS SUBWOOFERS

EPICX12 D2 | EPICX12 D4

User Guide

Important Safety Instructions

1. Read these instructions.
2. Keep these instructions.
3. Heed all warnings.
4. Follow all instructions.
5. Do not submerge this apparatus in water.
6. Clean only with a dry cloth.
7. **SECURE MOUNTING** (trust us—it matters): Mounting your subwoofer enclosure properly isn't just about keeping things clean—it's about keeping things safe. A loose subwoofer enclosure can turn into an unexpected passenger during a hard stop or sharp turn, and let's be honest, nobody wants to get hit in the back of the head by their own bass system. Even more, a poorly placed or unsecured enclosure can mess with important stuff like fuel lines, brake lines, or electrical wiring—things you definitely don't want to discover the hard way. So before grabbing the drill, take a moment to check what's behind or underneath your mounting area (call in a pro if you're unsure).
8. Use speaker wire of sufficient size to ensure adequate current to the speaker. For **EPICX** Subwoofers, this means 10-14 gauge speaker wire.
9. To prevent excessive cone excursion and potential damage to the subwoofer, it is advisable to use an infrasonic (subsonic) filter set half an octave below Fb (the enclosure's tuning frequency).
10. Refer all servicing to qualified service personnel. Servicing is required when the apparatus has been damaged in any way, such as the power input terminals are damaged, objects have fallen into the apparatus, does not operate normally, or has been dropped.
11. Exposure to high sound pressure levels may lead to permanent hearing loss. Take every precaution to protect your hearing.



The exclamation point within an equilateral triangle is intended to alert the user of the presence of important operating and maintenance (servicing) instructions in the literature accompanying the appliance.



Recycling notice: If the time comes and this apparatus has fulfilled its destiny, do not throw it out into the trash. It has to be carefully recycled for the good of mankind, by a facility specially equipped for the safe recycling of electronic apparatus. Please contact your local or state recycling leaders for assistance in locating a suitable nearby recycling facility. Or, contact us and we might be able to repair it for you.

Specifications - EPICX12 D2/D4

Speaker size	12 in / 300 mm
Impedance.....	EPICX12 D2 - 2 ohms
.....	EPICX12 D4 - 4 ohms
Voice Coil.....	2.38 in / 60 mm
Resonant Frequency	30.1 Hz
Efficiency	86.6 dB
Magnet Dimensions	6.14 x 2.95 x 0.98 in / 156 x 75 x 25 mm

Speaker Music Power

MIN	RMS	MAX
400	500	750

The power handling of the **EPICX12** varies depending on the enclosure the subwoofer is installed in. Please see below to determine the enclosure type and its power handling capabilities.

1. Sealed enclosure – 500 W RMS
2. Vented enclosure – 500 W RMS
3. Large vented enclosure – 400 W RMS

In the case of an oversized vented enclosure, reduced power is needed to control the woofer's excursion and maintain high efficiency.

Dimensions

Overall Diameter (A).....	12.4 in / 316 mm
Cut Out Diameter (B).....	11.06 in / 281 mm
Mounting Depth (C).....	6 in / 153.8 mm
Mounting Height (D).....	1 in / 24 mm
Motor Diameter (w/Cover) (E).....	6.4 in / 162 mm

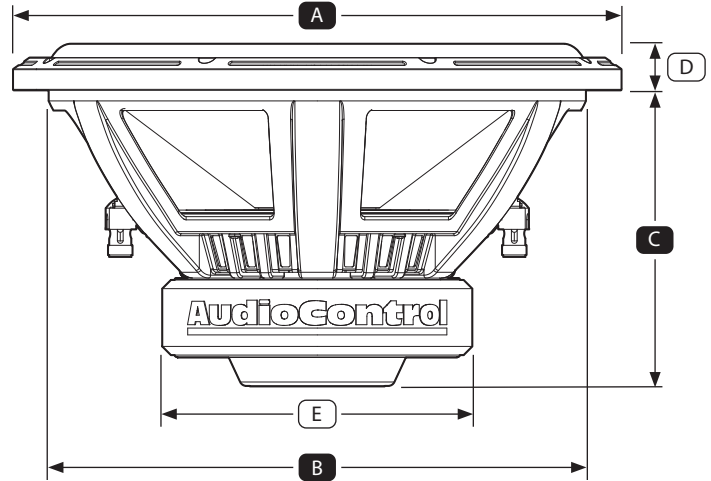

TS Parameters

Below are the TS parameters related to the **EPICX12 D2/D4** subwoofer. These specifications are intended for use in designing and modeling custom enclosures to ensure optimal performance.

	EPICX12 D2	EPICX12 D4
QES	0.586	0.737
QMS	5.74	5.88
QTS	0.533	0.655
Fs	32.6 Hz	34.5 Hz
VAS	59.2 L	43.5 L
MMS	196.87 g	181.35 g
CMS	0.121 mm/N	0.118 mm/N
RMS	7.13Ns/m	6.67Ns/m
RE	3.6 Ω	6.4 Ω
BL	15.75 T.m	18.48 T.m
LE	3.08 mH	4.61 mH
SD	515 cm ²	515 cm ²
XMAX	8.5 mm (one way)	8.5 mm (one way)
Sensitivity	86.3 dB @ 1W/1m	85.8 dB @ 1W/1m

We have half a mind to leave this page half blank.

TS parameters are measured after a 8 to 12 hour break-in period and may change slightly with use. They can also vary marginally between production batches.

System Wiring / Single Subwoofer / Series

Wiring a dual voice coil subwoofer in series doubles the impedance the amplifier sees. Connect one voice coil's negative terminal to the other voice coil's positive terminal to form a bridge. Connect the amp's positive output to the first voice coil's open positive terminal, and the amp's negative output to the second voice coil's open negative terminal.

EPICX12 D2 (2Ω) = 4Ω

EPICX12 D4 (4Ω) = 8Ω

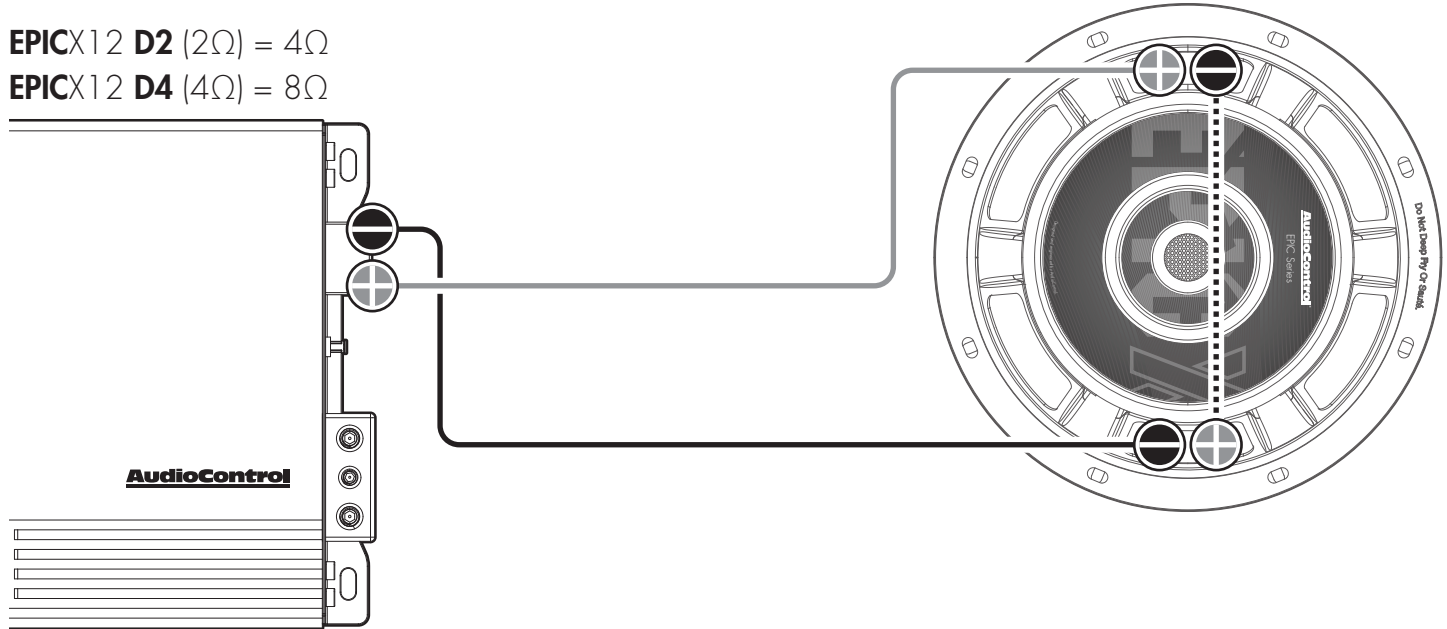

System Wiring / Single Subwoofer / Parallel

Wiring a dual voice coil subwoofer in parallel cuts the impedance the amplifier sees in half. Connect both positive voice coil terminals together, and both negative voice coil terminals together. Connect the amp's positive output to the joined positive terminals, and the amp's negative to the joined negative terminals.

EPICX12 D2 (2Ω) = 1Ω

EPICX12 D4 (4Ω) = 2Ω

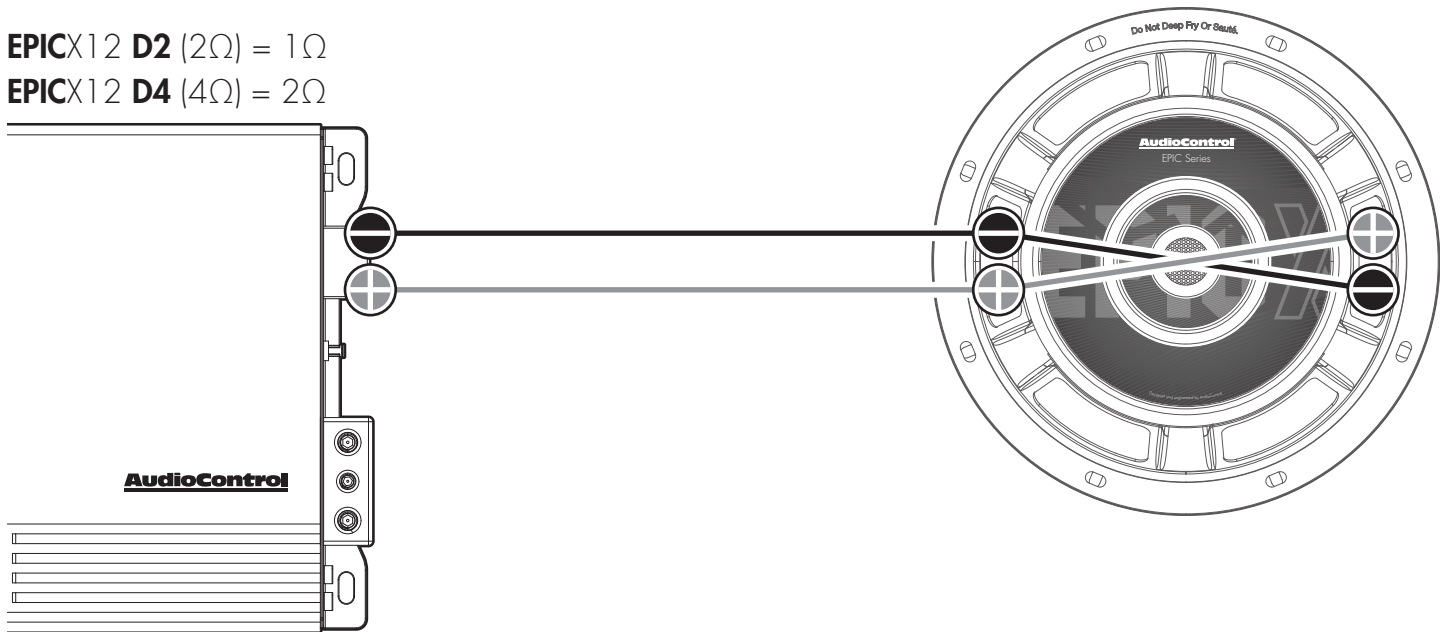

System Wiring / Two Subwoofers / Series-Parallel

Connect one voice coil's negative terminal to the other voice coil's positive terminal to form a bridge—do this on both subwoofers. Connect the remaining open terminals on each subwoofer together, positive to positive, negative to negative. Connect the amp's positive output to the joined positives terminals, and the amp's negative output to the joined negative terminals.

EPICX12 D2 (2Ω) = 2Ω

EPICX12 D4 (4Ω) = 4Ω

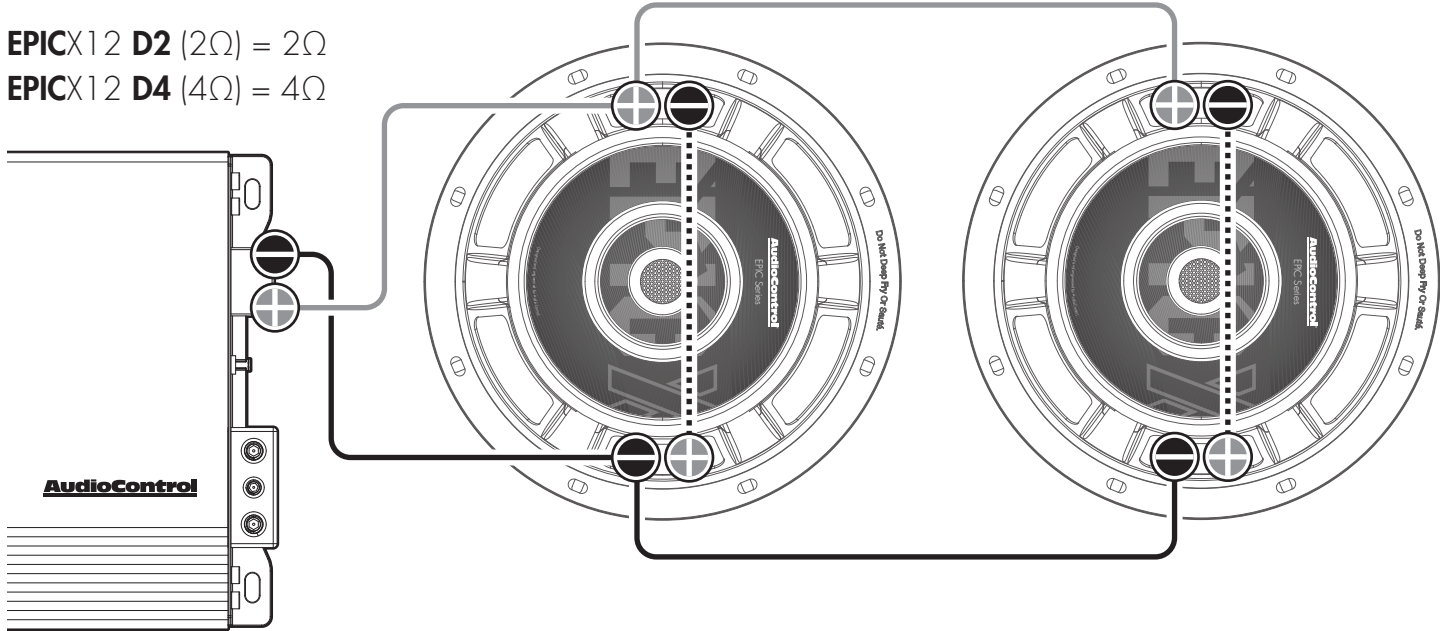

System Wiring / Two Subwoofers / Parallel

Connect both positive voice coil terminals together, and both negative voice coil terminals together—do this on both subwoofers. Connect the amp's positive output to the joined positive terminals on each subwoofer, and the amp's negative output to the joined negative terminals on each subwoofer.

EPICX12 D2 (2Ω) = ⚠

EPICX12 D4 (4Ω) = 1Ω

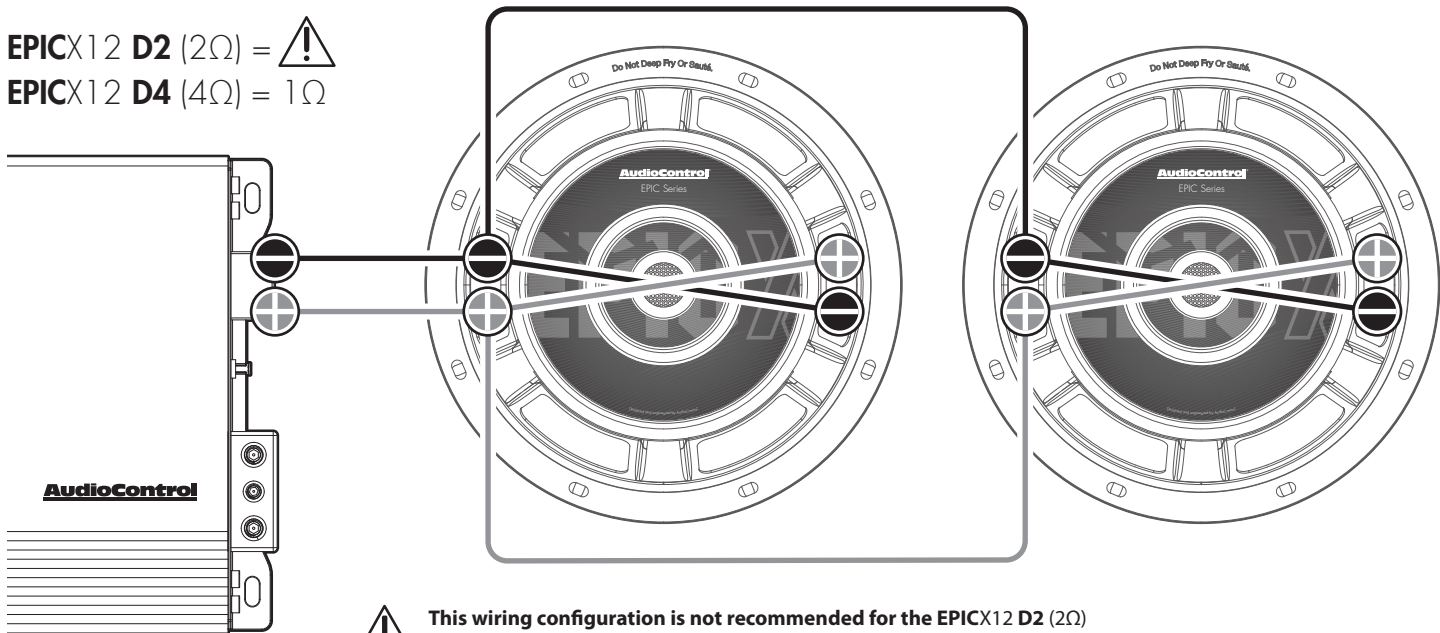

This wiring configuration is not recommended for the EPICX12 D2 (2Ω) subwoofer! This configuration would result in a 0.5Ω load.

There is already a fine selection of blank stares filling this space.
Feel free to contribute yours before moving on.

Enclosure Talk

Impressive! You picked up an **EPICX** subwoofer—or maybe even a few! After you're done admiring the quality workmanship and attention to detail, it's time to get it into a proper enclosure. "Enclosure" is just a fancy name for a speaker box. Below are some tips you should consider before buying or building one. If you're not into math, or if plugging in power tools gives you anxiety, your best bet is to seek out a qualified AudioControl dealer. They've got the skills, the experience, and the specialized tools to get the bass bumpin'—and they usually smell alright, too.

Sealed vs. Ported Enclosure

Aaahh... The age-old question: Which is better, a sealed or ported enclosure? The answer usually boils down to two factors: available space in the vehicle, and personal music preference. Below are a few characteristics of sealed and ported enclosures:

Sealed Enclosures

- Smaller enclosure size
- Excellent transient response
- Less output per watt, but punchier, tighter sound
- Lower dynamic output

Ported/Vented Enclosure

- Larger enclosure size
- Extended lower frequency response
- More bass output per watt
- Better dynamic output

If you have the space, we recommend a slot vented enclosure for the best all-around bass experience.

Enclosure Size... It Matters

Once you've decided on a sealed or ported enclosure, you can fine-tune its size to match your vehicle space and listening preferences.

Below is how enclosure size affects overall sound:

MIN **IDEAL** **MAX** The **MIN** value is the smallest recommended enclosure size, providing the most compact size, while sacrificing some low-frequency bass response.

MIN **IDEAL** **MAX** The **IDEAL** value is recommended for most listeners, providing an excellent blend of low-frequency bass with accurate and strong overall output.

MIN **IDEAL** **MAX** The **MAX** value is the largest recommended enclosure size, and although it is quite large, it provides exceptional bass with extended low-frequency output.

More enclosure designs!

On the following pages, we've included a selection of enclosure designs to help you hit the ground running with your new **EPICX** subwoofer—but this is just the beginning. For more designs and inspiration, scan the QR code with your phone!



Ported Enclosure

Below are the specifications for a vented enclosure designed to deliver balanced, powerful bass performance from your **EPICX12 D2** or **D4** subwoofer.

Specifications

Length (A).....	23.75 in
Height(B).....	16.5 in
Depth (C)	12.5 in
Exterior Volume.....	2.83 cu ft
Net Internal Volume (with Port and Subwoofer).....	2 cu ft
Material Thickness.....	0.75 in
Port Area.....	22.5 sq in
Port Inlet.....	1.2 in x 15 in
Port Length.....	23.75 in
Tuning Frequency	33 Hz

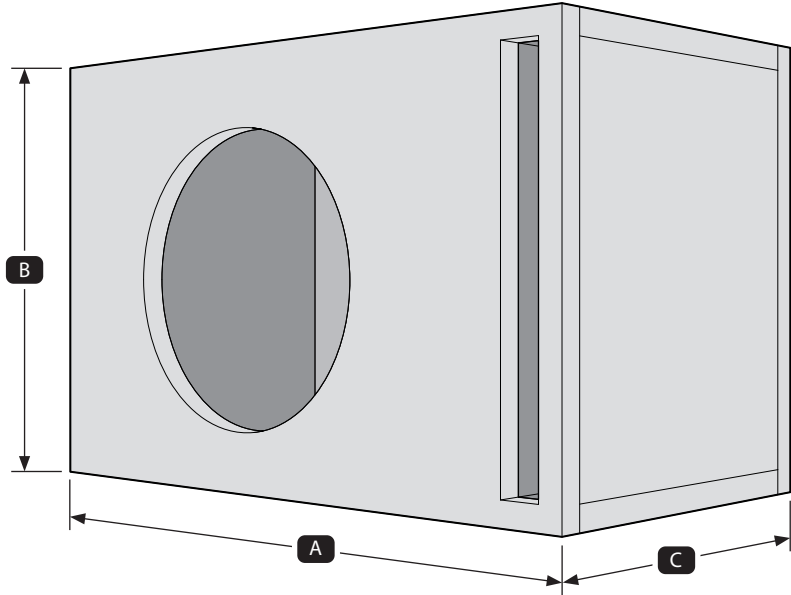

Sealed Enclosures

Below are the specifications for sealed enclosures in three sizes from small to large. Refer back to page 10 for more on how enclosure size affects sound.

MIN IDEAL MAX

Length (A)..... 15.5 in
 Height(B)..... 14.5 in
 Depth (C) 11 in
 Internal Volume..... 1 cu ft
 Material Thickness.....0.75 in

MIN IDEAL MAX

Length (A)..... 19 in
 Height(B)..... 14.5 in
 Depth (C) 11 in
 Internal Volume.....1.25 cu ft
 Material Thickness.....0.75 in

MIN IDEAL MAX

Length (A)..... 22.5 in
 Height(B)..... 14.5 in
 Depth (C) 11 in
 Internal Volume..... 1.5 cu ft
 Material Thickness.....0.75 in

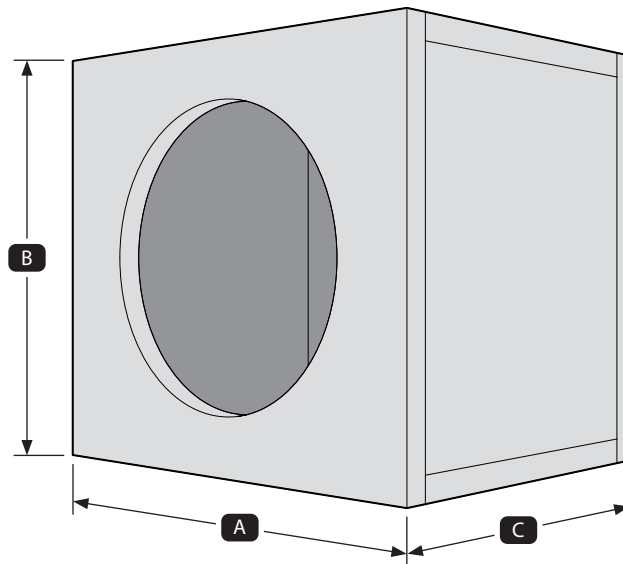

The Warranty

In just the same way as walking into a room and seeing a big hairy spider on the wall, people are scared of warranties. Lots of fine print. Months of waiting around. Well, fear no more. This warranty is designed to make you rave about AudioControl. It's a warranty that looks out for you and your client, plus helps you resist the temptation to have your friend Sparky, who's "good with electronics," try to repair your AudioControl product. So go ahead, read this warranty, then register the information at www.audiocontrol.com/product-registration and include your comments.

Our warranty has conditional conditions! "Conditional" doesn't mean anything ominous. The Federal Trade Commission tells all manufacturers to use the term to indicate that certain conditions have to be met before they'll honor the warranty. If you meet all of these conditions, AudioControl will, at its discretion, repair or replace any AudioControl speaker products that exhibit defects in materials and/or workmanship for one (1) year from the date you bought it. We will repair or replace it, at our option, during that time.

Here are the conditional conditions:

1. You must fully register your purchase within 15 days of the purchase date by going to the AudioControl product registration page at:
www.audiocontrol.com/product-registration
Failure to register your product will negate the warranty.
2. You need to hold on to your sales receipt! All warranty service requires original sales receipt documentation. The warranty only applies to the original purchaser from an authorized AudioControl dealer. Note: Products purchased from unauthorized dealers are not covered under warranty.

3. The AudioControl speaker products must have originally been purchased from an authorized AudioControl dealer. **If an authorized AudioControl dealer installs your AudioControl product, the warranty is extended to two (2) years.**
4. Our warranty covers AudioControl products that have been installed according to the instructions in this manual.
5. You cannot let anyone who isn't: (A) the AudioControl factory; or (B) someone authorized in writing by AudioControl, service your AudioControl product. If anyone other than (A), or (B) messes with your AudioControl product, the warranty is void.
6. The warranty is void if the serial number is altered, defaced or removed, or if your product has been used improperly. Now that may sound like a big loophole, but here is what we mean by this: Unwarranted abuse is: (A) physical damage (don't use your product to pound in fence posts); (B) improper connections (120 volts into the speaker terminals can fry the poor thing). This is the best product we know how to build, but for example, if you mount it to the front bumper of your car, drop it over Niagara Falls, or use it for anchoring your boat, something will go wrong.

Assuming you conform to 1 through 6, and it really isn't all that hard to do, we get the option of fixing your product, or replacing it with a new one, at our discretion.

In the event that your product is out of warranty or not covered under our warranty, you may request to have any damage repaired at our normal "Out of Warranty" repair cost.

Legalese

The warranty above is the only warranty issued by AudioControl. This warranty gives you specific legal rights, and you may also have rights that vary from state to state.

Promises of how well your AudioControl product will work are not implied by this warranty. Other than what we've said we'll do in this warranty, we have no obligation, express or implied. We make no warranty of merchantability or fitness for any particular purpose. Also neither we nor anyone else who has been involved in the development or manufacture of the unit will have any liability of any incidental, consequential, special or punitive damages, including but not limited to any lost profits or damage to other parts of your system by hooking up to the unit (whether the claim is one for breach of warranty, negligence of other tort, or any other kind of claim). Some states do not allow limitations of consequential damages.

For more information about this fine product, and for additional details of the limited warranty and repair services, please visit www.audiocontrol.com

For technical questions, please visit www.audiocontrol.com/knowledge-base/

AudioControl – “a Stinger Company”

9620 Executive Center Dr N, Suite 200
St Petersburg, FL 33702

Support:

Phone: 425-777-7723

Email: support@audiocontrolmobile.com

©2025 AudioControl. All rights reserved.

As technology advances, AudioControl reserves the right to continuously change our specifications, like our Pacific Northwest weather, although we are working on changing that as well.

